



# Process Gauges

## Portable 3" Test Gauges

### DESCRIPTION

U.S. Gauge 3" test gauges combine high accuracy, rugged construction and portability for a wide range of field and production testing applications.

Instruments are available in chrome plated brass Series 508/1408, as well as in economical, lightweight ABS chrome plated Series 1409 case designs. Optional felt-lined cover protects window against scratching or breakage. Test gauges incorporate diaphragm capsules or bourdon tube sensing elements for a wide selection of ranges from 30" Hg vacuum up to 5000 psi. A knife-edged, adjustable pointer improves viewing and simplifies front zero calibration.

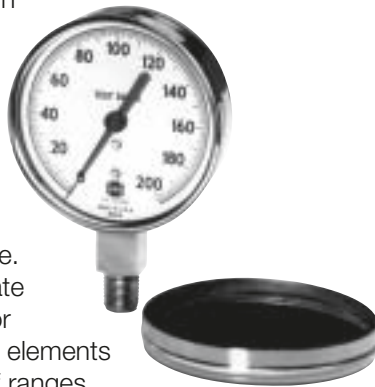

### SPECIFICATIONS

- DIAL SIZE:** 3"
- CASE:** 508, 1408: Brass, polished chrome finish; 1409: ABS, chrome plated
- RING:** 508, 1408: Brass, polished chrome, threaded; 1409: ABS, chrome plated
- COVER (Optional):** 508, 1408: Brass, polished chrome finish; 1409: ABS, chrome plated
- WINDOW:** 508, 1408: Polycarbonate; 1409: Polycarbonate
- POINTER:** Knife-edged, black, adjustable
- DIAL:** Steel, white background with black markings. Arc of calibration is 270° on 508. Arc of calibration on 1408 and 1409 is 300° except 0 to 5000 psi range arc is 270°
- MOVEMENT:** Geared with moving parts of dissimilar metals to minimize friction and wear
- PRESSURE ELEMENT:**  
 508: Diaphragm, Ni-Span-C  
 Bourdon Tube: 1408, 1409  
 Phosphor bronze: 30 through 1000 psi  
 Beryllium copper: 1500 through 5000 psi
- CONNECTION:** 1/4-18 ANPT low mount, brass
- ACCURACY:**  
 ±0.5% of span in 0 to 30" Hg VAC through 0 to 1000 psi (Grade 2A)  
 ±1% of span in 0 to 1500 psi through 0 to 5000 psi (Grade 1A)

### STANDARD RANGES

MAXIMUM INDICATION	FIGURE INTERVALS	SMALLEST INTERVALS
<b>Model 508</b>		
30" Hg VAC	5" Hg VAC	0.2" Hg VAC
5	1	0.05
10	1	0.1
15	3	0.1
<b>Models 1408 and 1409</b>		
30	2	0.1
60	5	0.2
100	10	0.5
160	10	1
200	20	1
300	20	1
600	50	2
1000	100	5
1500	150	10
2000	200	10
3000	500	20
5000	500	25

Pressure ranges in psi unless otherwise indicated

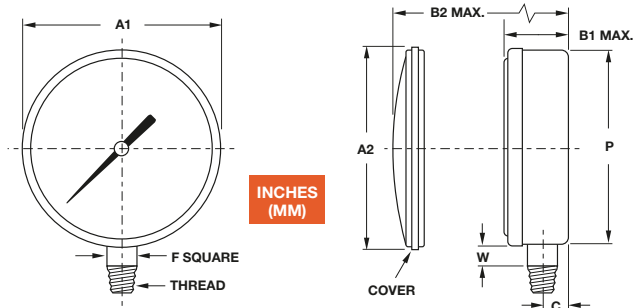

MODEL	UNIT	A1	A2	B1	B2	C	F	P	W
508 (3")	inches	3.22	3.33	1.64	1.96	.63	.555	3.12	.36
	mm	81.79	85.34	41.66	49.53	16.00	14.10	79.25	7.37
1408 (3")	inches	3.22	3.33	1.26	1.58	.42	.625	3.13	.77
	mm	81.79	85.34	32.00	40.39	11.18	15.85	79.50	17.78
1409 (3")	inches	3.40	3.55	1.38	1.69	.54	.625	3.23	.67
	mm	86.36	90.17	35.81	40.64	13.72	16.00	82.04	17.02

© 2002, by AMETEK, Inc. All rights reserved. 15M1102A (160126) Specifications are subject to change without notice. Visit our Web sites for the most up-to-date information.



**For Gauges/Thermometers:**  
**U.S. GAUGE**  
 820 Pennsylvania Blvd.  
 Feasterville, PA 19053 U.S.A.  
 Tel: (215) 355-6900  
 Fax: (215) 354-1802  
 www.ametekusg.com

Customer Service Tel: (863) 534-1504  
 Customer Service Fax: (863) 533-7465

**For Electronic Products:**  
**PMT PRODUCTS**  
 820 Pennsylvania Blvd.  
 Feasterville, PA 19053 U.S.A.  
 Tel: (215) 355-6900  
 Fax: (215) 354-1800  
 www.ametekusg.com

**For Diaphragm Seals:**  
**M&G PRODUCTS**  
 8600 Somerset Drive  
 Largo, FL 33773 U.S.A.  
 Tel: (727) 536-7831  
 Fax: (727) 539-6882  
 www.ametek.com/tci





# Process Gauges

## Portable 3" Test Gauges

### SPEC NUMBER SELECTION CHART

3" Portable Test Gauges	Model No. 508 1/4-18 ANPT, Low Mount	Model No. 1408 1/4-18 ANPT, Low Mount	Model No. 1409 1/4-18 ANPT, Low Mount
<b>Bourdon Tube</b>	<b>Diaphragm, Ni-Span C</b>	<b>Phosphor Bronze</b> (30 psi through 1000 psi) <b>Beryllium Copper</b> (1,500 psi through 5,000 psi)	<b>Phosphor Bronze</b> (30 psi through 1000 psi) <b>Beryllium Copper</b> (1,500 psi through 5,000 psi)
<b>Connection</b>	<b>Brass</b>	<b>Brass</b>	<b>Brass</b>
<b>Range</b>	<b>Spec No.</b>	<b>Spec No.</b>	<b>Spec No.</b>
0-30" Hg	13257	-	-
0-5 psi	47864	-	-
0-10 psi	47865	-	-
0-15 psi	12309	-	-
0-30 psi	-	44578	161947
0-60 psi	-	44579	161948
0-100 psi	-	44580	161949
0-160 psi	-	44581	161950
0-200 psi	-	44582	161951
0-300 psi	-	44583	161952
0-600 psi	-	44584	161953
0-1000 psi	-	44585	161954
0-1500 psi	-	78875	161955
0-2000 psi	-	52513	161956
0-3000 psi	-	149690	161957
0-5000 psi	-	50315	161958
Optional Protective Cap	152459	152459	161959

© 2002, by AMETEK, Inc. All rights reserved. 15M1102A (160126) Specifications are subject to change without notice. Visit our Web sites for the most up-to-date information.



*For Gauges/Thermometers:*  
**U.S. GAUGE**  
 820 Pennsylvania Blvd.  
 Feasterville, PA 19053 U.S.A.  
 Tel: (215) 355-6900  
 Fax: (215) 354-1802  
 www.ametekusg.com

Customer Service Tel: (863) 534-1504  
 Customer Service Fax: (863) 533-7465

*For Electronic Products:*  
**PMT PRODUCTS**  
 820 Pennsylvania Blvd.  
 Feasterville, PA 19053 U.S.A.  
 Tel: (215) 355-6900  
 Fax: (215) 354-1800  
 www.ametekusg.com

*For Diaphragm Seals:*  
**M&G PRODUCTS**  
 8600 Somerset Drive  
 Largo, FL 33773 U.S.A.  
 Tel: (727) 536-7831  
 Fax: (727) 539-6882  
 www.ametek.com/tci

