

LEVEL TRANSMITTERS

Model 575P Submersible Level Transmitter

Intrinsically Safe for Sewage Applications

FEATURES

- ◆ CSA approved for intrinsically safe operation
- ◆ Solid state semiconductor sensor for accuracy and reliability
- ◆ Rugged 316 stainless steel housing with excellent environmental protection
- ◆ HASTELLOY C diaphragm
- ◆ Easy to install and use
- ◆ 2 wire 4 to 20 mA output
- ◆ Vented to the atmosphere through the surface end of the cable
- ◆ Reverse polarity and surge protected
- ◆ Lightning protectors available
- ◆ Nonclogging, flush diaphragm
- ◆ EMI protection available

APPLICATIONS

- ◆ Water/wastewater treatment
- ◆ Lift stations
- ◆ Slurry/sludge
- ◆ Pump control
- ◆ Level control

DESCRIPTION

The Model 575P Submersible Level Transmitter, with its flush diaphragm, is specially designed to provide the convenience of direct submergence in many types of liquid, especially wastewater, for quick, accurate and reliable level measurement. The simple design and rugged construction of this solid state instrument provide long lasting service with virtually no maintenance.

The Model 575P Transmitter indicates the level of liquid by continuously measuring hydrostatic pressure via its sensing element, an ion implanted silicon semiconductor chip with integral Wheatstone Bridge circuit. Once the

sensor measures the pressure, the data is transmitted by a 4 to 20 mA output signal. This design provides for excellent linearity and repeatability, low hysteresis and long term stability.

The Model 575P is easy to install, too. Simply lower the transmitter into a tank. A special protective flange protects the probe's HASTELLOY C diaphragm. All the electronics are mounted in a submersible 316 stainless steel housing. A special cable support bracket is also available. This gives extra stability to the transmitter when used with longer lengths of cable or when used in an agitated liquid.

The transmitter is available calibrated



**MODEL 575P TRANSMITTER
INTRINSICALLY SAFE**

for any span needed, from 0 to 3 psi or 0 to 0.2 bar (0 to 7 feet or 0 to 2.1 meters of water) to 0 to 300 psi or 0 to 20 bar (0 to 690 feet or 0 to 211 meters of water).

To complete your liquid level measurement and control system, use the AMETEK Model DMC Digital Meter/Controller with the Model 575P Submersible Transmitter.

Model 575P Submersible Level Transmitter

SPECIFICATIONS

FEET OF WATER: 0/14, 0/35, 0/69, 0/138, 0/230, 0/345, 0/460, 0/690

METERS OF WATER: 0/4, 0/10, 0/21, 0/42, 0/70, 0/105, 0/140, 0/210

BAR: 0/0.4, 0/1, 0/2, 0/4, 0/7, 0/10, 0/14, 0/20

PSI: 0/6, 0/15, 0/30, 0/60, 0/100, 0/150, 0/200, 0/300

OUTPUT: 4 to 20 mA, 2 wire, current limited to 30 mA DC

POWER SUPPLY: 12 to 40 VDC with reverse polarity surge protection; Limited to 28 VDC for CSA I.S.

LOOP RESISTANCE: 1400 ohms maximum at 40 volts

TEMPERATURE RANGE*:

Ambient Operating: CSA intrinsically safe T3C = -25°F to 180°F (-32°C to 82°C)

Storage: -40°F to 180°F (-40°C to 82°C)

*If submerged in a liquid that has frozen, damage will result. Limit high temperature to 140°F (60°C) for intrinsically safe operation.

OVERRANGE EFFECT: ±0.15% full scale at 200% of maximum range

OVERRANGE LIMIT: 200% of maximum range

ACCURACY: ±0.25% full scale, BFSL (including linearity, hysteresis and repeatability); ±0.50% full scale (6 psi range only)

ZERO OFFSET: ±0.50% full scale set at 77°F (25°C)

SPAN: ±0.50% full scale set at 77°F (25°C)

TEMPERATURE EFFECTS: (15 psi and above)
Compensated: 23°F to 130°F (-5°C to 55°C); Maximum ±1% URL output change for ±25°C temperature change within compensated range when calibrated at 25°C. Consult factory for lower or alternate pressure ranges.

POWER SUPPLY EFFECT: ±0.005% full scale per volt

CONSTRUCTION:

Diaphragm: HASTELLOY C

Housing Type: 316 stainless steel

Nut/Washer Type: 316 stainless steel

Cable Grommet: Viton standard. Please contact factory for other options.

Housing O Ring: Viton standard. Please contact factory for other options.

Cable Jacket: Polyurethane

MEDIA COMPATIBILITY: Reference materials of construction

ELECTRICAL CONNECTION: Attached 20 gauge polyurethane shielded cable. Unspliced lengths available up to 5000 ft. (1662 m)

WEIGHT: 1 lb. 3 oz. (539 g)

APPROVALS: Meets CSA requirements for intrinsically safe operation in hazardous locations as designated by Class I, Div 1, Groups A, B, C & D and Class II, Groups E, F & G. Temperature Code T3C (when used with approved barrier).

SPECIFICATIONS SUBJECT TO CHANGE WITHOUT NOTICE

ORDERING INFORMATION

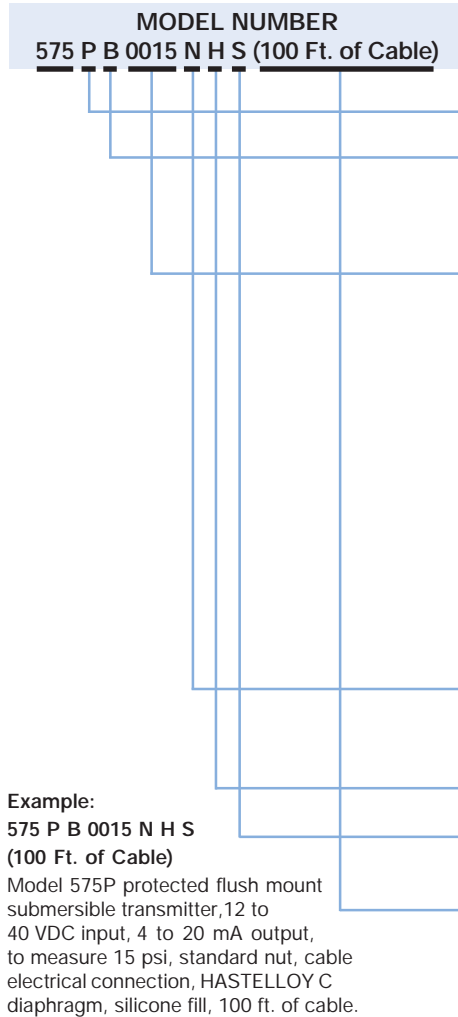

- SENSING PORT**
 P = Protected flush
- INPUT/OUTPUT**
 B = 12 to 40 VDC/4 to 20 mA
Consult factory for availability of different input/output options
- RANGE**
 0006 = 0 to 6 psi/0 to 0.4 bar (0 to 14 ft./0 to 4.2 m water)
 0015 = 0 to 15 psi/0 to 1 bar (0 to 35 ft./0 to 10.5 m water)
 0030 = 0 to 30 psi/0 to 2 bar (0 to 69 ft./0 to 21.1 m water)
 0060 = 0 to 60 psi/0 to 4 bar (0 to 138 ft./0 to 42.2 m water)
 0100 = 0 to 100 psi/0 to 7 bar (0 to 230 ft./0 to 70.3 m water)
 0150 = 0 to 150 psi/0 to 10 bar (0 to 345 ft./0 to 105.4 m water)
 0200 = 0 to 200 psi/0 to 14 bar (0 to 460 ft./0 to 140.5 m water)
 0300 = 0 to 300 psi/0 to 20 bar (0 to 690 ft./0 to 211.0 m water)
- Calibrated ranges can be specified after the model code; the specific range should be between the upper and lower ranges in the category selected.*
- ELECTRICAL CONNECTION**
 N = Standard nut/cable
 R = Cable support with standard nut/cable
 C = Conduit adaptor
- DIAPHRAGM**
 H = HASTELLOY C diaphragm
- FILL**
 S = Silicone oil
 Others = Consult factory for availability.
- CABLE LENGTH**
 (Specify length in feet)
- NOTE:** Unspliced lengths available up to 5000 ft. (1662 m). Please contact factory for other options.

DIMENSIONS

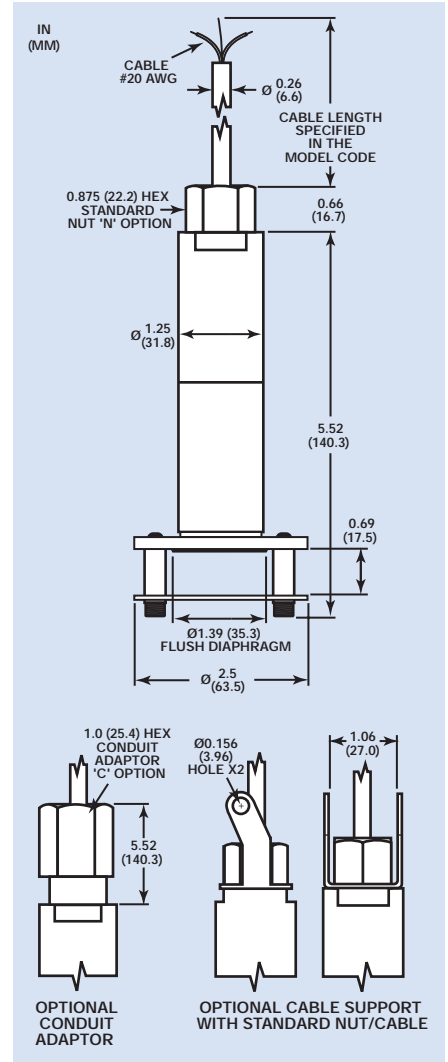

U.S. GAUGE • PMT PRODUCTS

820 PENNSYLVANIA BLVD., FEASTERTVILLE, PENNSYLVANIA 19053 U.S.A.
 TEL: (215) 355-6900 • FAX: (215) 354-1800 • www.ametekusg.com



© 2003, by AMETEK, Inc. All rights reserved.
 2.5M1203CW (110068)