



### Features

- Explosion-proof NEMA 4X, IP65, Type 4 enclosure for outdoor and indoor installations.
- Optional tapped exhaust port vents exhaust gas.
- Canadian Registration Numbers (CRN) certification for all territories and provinces.
- Does not contain copper-based metals.
- Compact size for use in restricted areas.
- Internal electronic feedback maintains precise output pressure control.
- Piezoelectric actuator disk provides stability regardless of vibration or position.
- RFI/EMI protection eliminates susceptibility to electromagnetic interference.
- Optional version approved for use with Natural Gas or Industrial Methane as a supply media.
- Encapsulated critical components designed to make unit moisture resistant in tough environments

### Operating Principles

The Model TXI7850 transducer is an electronically controlled pressure sensitive device that converts a current signal to a pneumatic output. This device is composed of the Primary Converting Section and the Relay Section. The Piezoelectric ceramic disk in the Primary Section functions as a flapper. The flapper and the nozzle work together to control the signal pressure in the Relay Section. The signal pressure acts on a diaphragm assembly that controls the pressure in the output chamber.

The output pressure is sensed by the lower control diaphragm to maintain the output pressure. The output pressure is also sensed by the feedback control circuit, which compares the output pressure and input signal (setpoint) to maintain constant output pressure.

The Damping Adjustment on the PC Board allows tuning the transducer for optimum response and stability. Large downstream volumes generally require more damping to achieve output pressure stability.

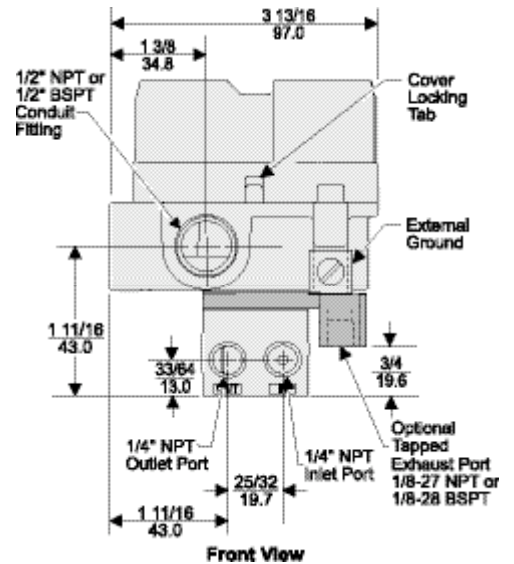
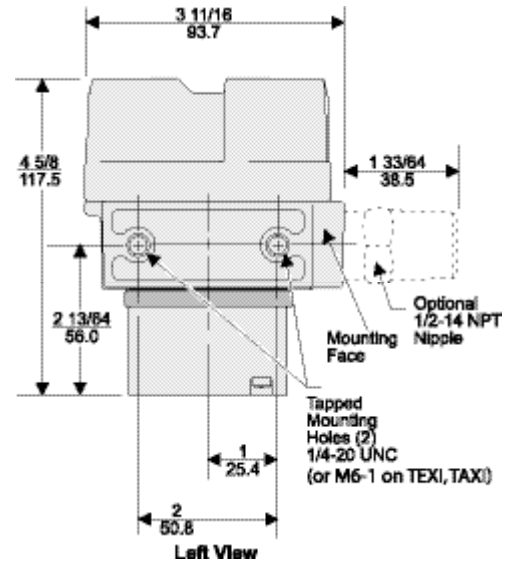
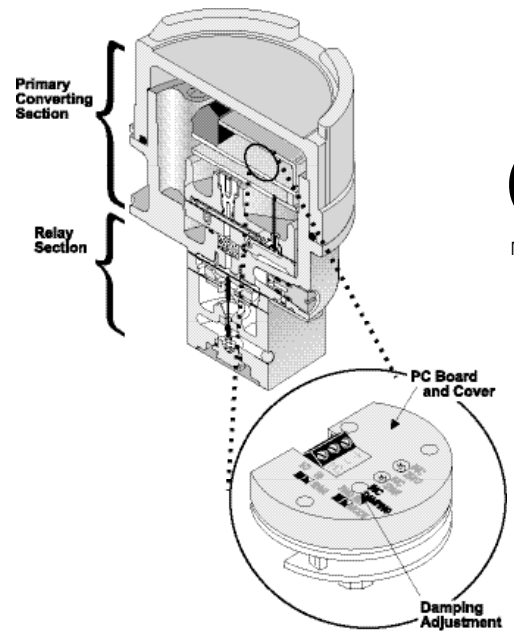

**B**  
Model TXI 7850

# Model TXI7850 Moisture Resistant Electro-Pneumatic Transducer





## Specifications

		SET POINT			
		3 [0.2] (20)	9 [0.6] (60)	15 [1.0] (100)	30 [2.0] (200)
<b>Maximum Air Consumption</b>	<b>psig [BAR] (kPa)</b> <b>SCFH</b>	3.5 (.10 m <sup>3</sup> /HR)	7.0 (.20 m <sup>3</sup> /HR)	9.5 (.27 m <sup>3</sup> /HR)	13.5 (.38 m <sup>3</sup> /HR)
<b>Flow Rate (SCFM)</b>		2.5 (4.25 m <sup>3</sup> /HR) @ 25 psig, [1.7 BAR], (170 kPa) supply & 9 psig, [0.6 BAR], (60 kPa) Output		9.0 (15.3 m <sup>3</sup> /HR) @ 120 psig, [8.0 BAR], (800 kPa) supply & 9 psig, [0.6 BAR], (60 kPa) Output	
<b>Temperature Range</b>	<b>Operating Storage</b>	-40°F to + 160°F (-40°C to + 71. 2°C) -40°F to + 180°F (-40°C to + 82.2°C)			
<b>Span/Zero Adjustments</b>		Screwdriver adjustments located under cover			
		OUTPUT RANGE			
		3-15 [0.2-1.0] (20-100)	3-27 [0.2-1.8] (20-180)	6-30 [0.4-2.0] (40-200)	
<b>Input Range</b>	<b>psig [BAR] (kPa)</b>	4-20 mA			
<b>Supply Pressure<sup>1,2</sup></b>		20-120 [1.5-8.0] (150-800)	32-120 [2.2-8.0] (220-800)	35-120 [2.4-8.0] (240-800)	
<b>Minimum Span</b>		5 [0.35] (35)	10 [0.7] (70)	10 [0.7] (70)	
<b>Frequency Response</b>		-3 db @ 5 Hz per ISA S26.4.3.1 load configuration A.			
<b>Required Operating Voltages</b>		7.2 VDC @ 20 mA (4-20 mA signal)			
<b>Accuracy (ISA S51.1)</b>		0.25% Full Scale Guaranteed 0.15% Full Scale Typical			
<b>Hysteresis (ISA S51.1)</b>		0.1% Full Scale			
<b>Deadband</b>		0.02% Full Scale			
<b>Repeatability (ISA S51.1)</b>		0.1% Full Scale			
<b>Position Effect</b>		No Measurable Effect			
<b>Vibration Effect</b>		Less than ±1% of Span under the following conditions: 5-15 Hz @ 0.75 inches constant displacement 15-500 Hz @ 10 Gs.			
<b>Reverse Polarity Protection</b>		No damage occurs from reversal of normal supply current (4-20 mA) or from misapplication of up to 60 mA.			
<b>RFI/EMI Effect</b>		Less than 0.5% of span @ 30 $\mu$ m class 3 Band ABC (20-1000 mHz) per SAMA PMC 33.1 1978 and less than 0.5% of Span @ 10 $\mu$ m level, to 2 GHz Band per EN 61000-4-3:1998 +A1 EMC Directive 89/336/EEC European Norms EN 61326			
<b>Supply Pressure Effect</b>		No Measurable Effect			
<b>Temperature Effect</b>		[+0.5% +0.04% / °F Temperature Change] of Span typical			
<b>Materials of Construction</b>		Body and Housing .....Chromate Treated Aluminum Orifice .....Aluminum & Sapphire Trim .....Stainless Steel & Zinc Plated Steel Elastomers .....Nitrile Finish .....Epoxy Powder Coating			

<sup>1</sup> Supply Pressure must be no less than 5 psig, [0.35 BAR], (35 kPa), above maximum output.

<sup>2</sup> Atex Approved unit 40 psig, [2.8 BAR], (280 kPa). Atex Approved unit with "N" option 120 psig, [8.0 BAR], (800 kPa) for Air or Group IIA gases.

Hazardous Area Classifications

	Explosion-Proof	Intrinsically Safe									
<b>Factory Mutual (FM) Approvals</b> 	<b>Air as supply pressure media</b> Class I, Division 1, Groups B, C and D; Class II, Division 1, Groups E, F and G; Class III, Division 1, Fibers; Class I, Division 2, Groups A, B, C and D; NEMA 4X Enclosure; Max. Ambient 65°C; Temperature Code T5.	<b>Air as supply pressure media</b> Class I, Division I, Groups C and D; Class II, Division 1, Groups E, F and G; Class III, Division 1; Fibers; NEMA 4X Enclosure; Max. Ambient 65°C; Temperature Code T4.									
	<b>Group D gases, including Natural Gas as supply pressure media</b> Class I, Division 1, Groups C and D; Class II, Division 1, Groups E, F and G; Class I, Division 2, Groups A, B, C and D; Class II, Division 2, Groups E, F and G.	<table border="1"> <tr> <td colspan="2"><b>Entity Parameters</b></td> </tr> <tr> <td><math>V_{max}^1 = 30 \text{ VDC}</math></td> <td><math>C_i^3 = 0 \mu\text{F}</math></td> </tr> <tr> <td><math>I_{max}^2 = 200 \text{ mA}</math></td> <td><math>L_i^4 = 0 \text{ mH}</math></td> </tr> <tr> <td><sup>1</sup><math>V_{max} = \text{Max. Voltage}</math></td> <td><sup>3</sup><math>C_i = \text{Capacitance}</math></td> </tr> <tr> <td><sup>2</sup><math>I_{max} = \text{Max. Current}</math></td> <td><sup>4</sup><math>L_i = \text{Inductance}</math></td> </tr> </table>	<b>Entity Parameters</b>		$V_{max}^1 = 30 \text{ VDC}$	$C_i^3 = 0 \mu\text{F}$	$I_{max}^2 = 200 \text{ mA}$	$L_i^4 = 0 \text{ mH}$	<sup>1</sup> $V_{max} = \text{Max. Voltage}$	<sup>3</sup> $C_i = \text{Capacitance}$	<sup>2</sup> $I_{max} = \text{Max. Current}$
<b>Entity Parameters</b>											
$V_{max}^1 = 30 \text{ VDC}$	$C_i^3 = 0 \mu\text{F}$										
$I_{max}^2 = 200 \text{ mA}$	$L_i^4 = 0 \text{ mH}$										
<sup>1</sup> $V_{max} = \text{Max. Voltage}$	<sup>3</sup> $C_i = \text{Capacitance}$										
<sup>2</sup> $I_{max} = \text{Max. Current}$	<sup>4</sup> $L_i = \text{Inductance}$										
<b>Canadian Standards Association (CSA) Approvals</b> 	<b>Air as supply pressure media</b> Class I, Division 1, Groups B, C and D; Class II, Division 1, Groups E, F and G; Class I, Division 2, Groups A, B, C and D; Class II, Division 2, Groups E, F and G. Type 4X Enclosure; Temperature Code T5; Max. Ambient 65°C.	<b>Air as supply pressure media</b> Class I, Division 1, Groups C and D; Class II, Division 1, Groups E, F and G; Type 4X Enclosure; Temperature Code T4; Rated 4 - 20 mA, 30 VDC maximum.									
	<b>Group D gases, including Natural Gas as supply pressure media</b> Class I, Division 1, Groups C and D; Class II, Division 1, Groups E, F and G; Class I, Division 2, Groups A, B, C and D. Class II, Division 2, Groups E, F and G. <b>Factory Sealed</b>	<p><b>Approvals are valid when connected through a Shunt Zener Diode Safety Barrier meeting the following parametric requirements:</b></p> <table border="1"> <tr> <td>System Type 1:</td> <td>Single Channel Polarized Rated: 28.5V Max. 300 Ohm Min.</td> </tr> <tr> <td>System Type 2:</td> <td>Dual Channel Polarized Rated 28.5V Max. 300 Ohm Min. and 28V Diode return per channel</td> </tr> <tr> <td>System Type 3:</td> <td>Dual Channel Polarized Rated: 28.5V Max. 300 Ohm Min. and 10V Max. 50 Ohm Min.</td> </tr> </table>	System Type 1:	Single Channel Polarized Rated: 28.5V Max. 300 Ohm Min.	System Type 2:	Dual Channel Polarized Rated 28.5V Max. 300 Ohm Min. and 28V Diode return per channel	System Type 3:	Dual Channel Polarized Rated: 28.5V Max. 300 Ohm Min. and 10V Max. 50 Ohm Min.			
System Type 1:	Single Channel Polarized Rated: 28.5V Max. 300 Ohm Min.										
System Type 2:	Dual Channel Polarized Rated 28.5V Max. 300 Ohm Min. and 28V Diode return per channel										
System Type 3:	Dual Channel Polarized Rated: 28.5V Max. 300 Ohm Min. and 10V Max. 50 Ohm Min.										
<b>Explosive Atmospheres Directive (ATEX) Approvals*</b>	<b>Flame-Proof</b> <b>Air as supply pressure media</b>  II 2 GD EEx d IIB + H <sub>2</sub> , T5 (-20°C to +65°C) Ambient; IP65 Enclosure.	<b>Intrinsically Safe</b> <b>Air as supply pressure media</b>  II 1 G (T4) II1D (T 85°C) EEx ia IIB, T4 (-20°C to +72°C) Ambient; IP65 Enclosure.									
	<b>Group IIA gases, including Natural Gas as supply pressure media</b>  II 2 GD EEx d IIB, T5 (-20°C to +65°C) Ambient; IP65 Enclosure.										

\* **Transducer Parameters**

$U_{max}^1 = 28 \text{ V}$	$P_i^3 = 0.7 \text{ W}$	$L_i^5 = 0$
$I_{max}^2 = 100 \text{ mA}$	$C_i^4 = 0$	
<sup>1</sup> $U_{max} = \text{Max. Voltage}$	<sup>3</sup> $P_i = \text{Max. Power}$	<sup>5</sup> $L_i = \text{Inductance}$
<sup>2</sup> $I_{max} = \text{Max. Current}$	<sup>4</sup> $C_i = \text{Capacitance}$	

**B**  
Model TXI 7850

# Model TXI7850 Moisture Resistant Electro-Pneumatic Transducer

## Mounting Kit

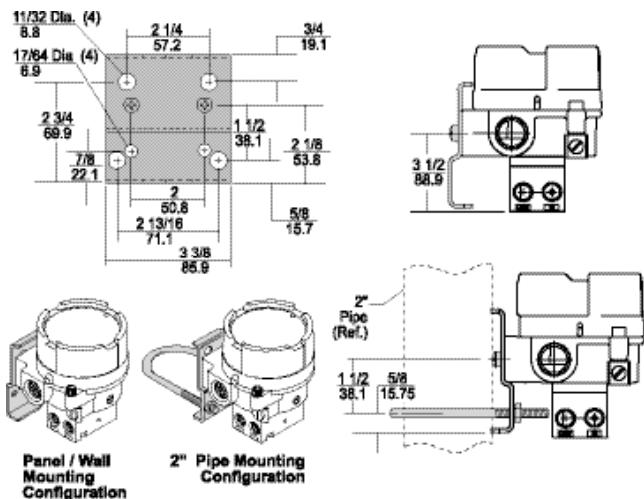

## Model TXI7850 Transducer Kits & Accessories

**Mounting Bracket Kits** .....19021-1: TCXI7850, TFXI7850  
(sold separately)  
19021-2: TEXI7850 (sold separately)

## Catalog Information

Catalog Number	T	X I 7850	4		
Underwriting Group					
Canadian Standard	C				
ATEX	E				
Factory Mutual	F				
Input					
4-20 mA			4		
Output					
3-15 psig				01	
3-27 psig				02	
6-30 psig				03	
0-30 psig <sup>4</sup>				04	
0-60 psig <sup>4</sup>				05	
0-120 psig <sup>4</sup>				06	
[0.2-1.0 BAR]				11	
[0.2-1.8 BAR]				12	
[0.4-2.0 BAR]				13	
[0-2.0 BAR] <sup>4</sup>				14	
[0-4.0 BAR] <sup>4</sup>				15	
[0-8.0 BAR] <sup>4</sup>				16	
(20-100 kPa)				21	
(20-180 kPa)				22	
(40-200 kPa)				23	
(0-200 kPa) <sup>4</sup>				24	
(0-400 kPa) <sup>4</sup>				25	
(0-800 kPa) <sup>4</sup>				26	
Options					
Tapped Exhaust					E
Natural Gas media approval, Group D gases					N
(Includes Nipple; TCXI, TEXI, TFXI only) <sup>1,2</sup>					
BSPT Thread <sup>3</sup>					U

<sup>1</sup> Not approved for Intrinsically Safe.

<sup>2</sup> Tapped Exhaust option required.

<sup>3</sup> Available for ATEX only. NOT available with "N" Option.

<sup>4</sup> Consult Factory for details and availability.

## Installation

For installation instructions, refer to the *Fairchild Model TXI7850 Explosion-proof Electro-pneumatic Transducer Installation, Installation Instructions, II-5TXI7850*.

For operation and maintenance instructions, refer to the *Fairchild Model TXI7850 Explosion-proof Electro-pneumatic Transducer Operation and Maintenance Instructions, OM-5TXI7850*.